

MINIMUM SPECIFICATION FOR
 (2) TRUCKS, PICK UP, ¾-TON, CREW CAB, 4X2, 2009 or NEWER
 Class Code 02-20-20-G, Battle Wagon, 12/15/09

	<u>PER SPEC.</u>
MAKES AND MODELS: NO SUBSTITUTES other than listed below:	
Chevrolet Silverado 2500 HD LT, <u>OR</u>	_____
Dodge Ram 2500 SLT, <u>OR</u>	_____
Ford F250 Super Duty XLT, <u>OR</u>	_____
GMC Sierra 2500 HD SLE	_____
YEAR:	
2009 or newer	_____
State year offered _____	_____
G.V.W.R.:	
9200 minimum	_____
W.B.:	
153" minimum, State _____	_____
ENGINE:	
5.4 L minimum, gasoline, State _____	_____
Oil filter _____	_____
AIR CLEANER:	
High capacity	_____
COOLING:	
Heavy Duty, Increased capacity (largest available for this model application)	_____
TRANSMISSION:	
Automatic 5-speed with overdrive	_____
Auxiliary oil cooler	_____
FRONT AXLE:	
Maximum capacity available	_____
State capacity offered _____	_____
REAR AXLE:	
Maximum capacity available	_____
State capacity offered _____	_____
Ratio 4.10	_____
HD Locking	_____
SUSPENSION PACKAGE:	
HD handling/trailering	_____
FRONT SPRINGS:	
Heavy duty, maximum for this model	_____
State capacity _____	_____
REAR SPRINGS:	
Heavy duty, maximum for this model	_____
State capacity _____	_____

MINIMUM SPECIFICATION FOR
 (2) TRUCKS, PICK UP, ¾-TON, CREW CAB, 4X2, 2009 or NEWER
 Class Code 02-20-20-G, Battle Wagon, 12/15/09

		<u>PER SPEC.</u>
CAB:	Crew cab 4-door	_____
	Arm rests	_____
	(2) Sun visors	_____
	Seat belts	_____
	Custom cloth split bench seat 40/20/40, or bucket seats with no center console	_____
	State Seat arrangement offered _____	_____
	Dark interior	_____
	Body side moldings	_____
BUMPERS:	Chrome front and rear with rear step	_____
SPARE TIRE:	Full size with carrier lock	
BEDLINER:	"Line X" spray in bedliner, black below the rail _____	
BED COVER:	"Gemtop" model "WorkMaster" steel shell	_____
	Gemtop shall be painted the same white as roof and doors of truck.	_____
	The following options shall be included on the Gemtop bed cover:	
	Option 3 B Drop down solid front window	_____
	Option 4 Security screen for fixed window	_____
	Option 5 Lift up side door on both sides	_____
	Option 6 Fixed window for lift up side doors	_____
	Option 8 Security screen for side windows	_____
	Lift up door at tailgate	_____
	Option 12 Rear window for lift up rear door	_____
	Option 13 Security screen for lift up rear door	_____
	One dome light shall be installed at each door opening.	_____
	Heavy-duty 4X4 package	_____
Option 56 Three point rotary latch on all doors	_____	
All windows shall be tinted	_____	
No exceptions shall be allowed for Gemtop Workmaster or options	_____	
TOW HOOKS:	Front frame mounted	_____
TRAILER PLUG:	Cole Hersee #1225 trailer plug installed in bumper and properly wired	_____
TRUCK COLOR:	Black with roof and doors white	_____

MINIMUM SPECIFICATION FOR
(2) TRUCKS, PICK UP, ¾-TON, CREW CAB, 4X2, 2009 or NEWER
Class Code 02-20-20-G, Battle Wagon, 12/15/09

		<u>PER SPEC.</u>
BED INTERIOR:	Shall be equipped with an "Extendo Bed" model EB-1272, rated at 1800lbs. capacity "Extendo Bed" rail system shall be equipped with a DPF-4872-21 Double Plywood Platform (see attached drawing) Refer to proposal #4783 for unit and vendor may contact Kerry Stimpson at 800 752-0706 for details. No exceptions shall be allowed for "Extendo Bed" or "DPF-4872-21"	_____ _____ _____ _____
KEYS:	Vehicles shall be delivered with three sets of keys, if equipped with remote keyless entry three key fobs shall also be provided	_____

This vehicle to meet the requirements of all applicable Federal and State agencies.

VENDOR DELIVERY DATE

Each bidder shall provide, in the space noted below, the maximum number of calendar days, after receipt of a purchase order, that will be required to deliver the vehicle or equipment as specified.

It is of the utmost concern to the City of Anaheim that the vendor-supplied delivery date be met. Any delays in delivery date as quoted herein shall be immediately reported in writing to the purchasing agent with a copy to the requesting department representative. Any change in the original quoted delivery date is subject to approval by the City.

However, the City of Anaheim reserves the right to cancel the purchase order for non-performance of quoted delivery at no cost or obligation to the City.

VENDOR DELIVERY: _____

AUTHORIZED REPRESENTATIVE: _____

DATE: _____

DELIVERY

Deliver to 955 S. Melrose, Anaheim, CA 92805. The invoice and all necessary vehicle registration documentation must accompany delivery.

PER SPEC.

EXTENDO BED COMPANY

1-800-752-0706

Proposal for City of Anaheim
for 2009/2010 3/4 ton short bed
Proposal #4783, December 1, 2009

Drawing Not
To Scale

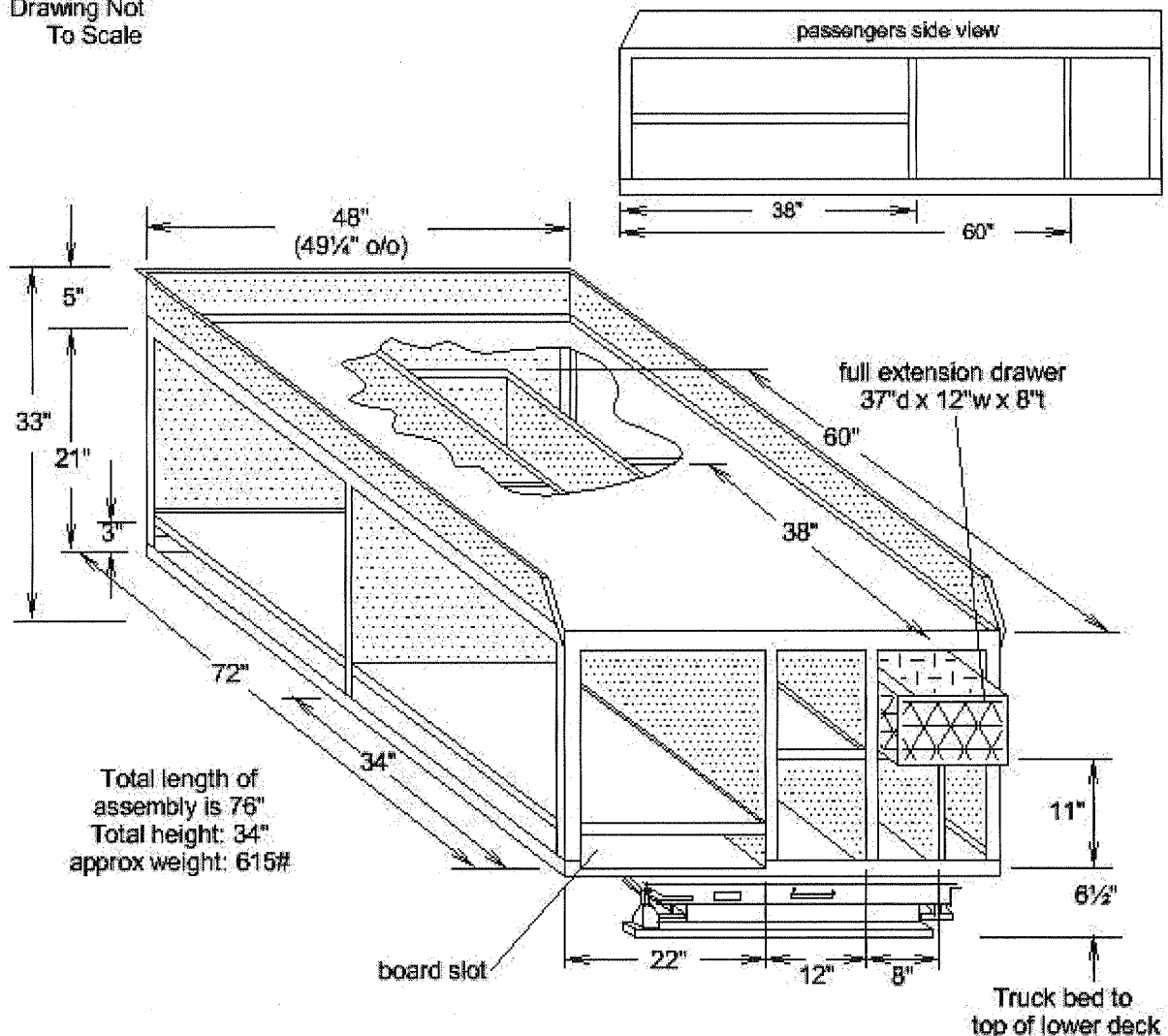

Lower platform will be 3/4" acx plywood w/ 1/2" acx plywood on upper shelving. Carrier will be built of 1 1/2" by 1/8" steel angle, with 1 1/2", 10 gauge steel mesh screening. Carrier & platform rails will be punched for bungee cord ties. Drawer will be of .080 diamond plate aluminum, on 300# capacity slides. Top of deck surfaces to be coated with a protective sealer. Optional deck coverings are: rubber mat and Rhino Lining.